

# Path Planning for a Differential Drive Robot : Minimal Length Paths-A Geometric Approach

Sourabh Bhattacharya Rafael Murrieta-Cid Seth Hutchinson

Department of Electrical and Computer Engineering  
Beckman Institute for Advanced Science and Technology  
University of Illinois at Urbana-Champaign  
{ sbhattac, murrieta, seth } @ uiuc.edu

**Abstract**— This work presents the minimal length paths, for a robot that maintains visibility of a landmark. The robot is a differential drive system and has limited sensing capabilities (range and angle of view). The optimal paths are composed of straight lines and curves that saturate the camera pan angle.

## I. INTRODUCTION

In this paper, we study the interaction of the nonholonomic and visibility constraints for a robot that maintains visibility of a stationary landmark. The robot is a differential drive system and has limited perception (range and angle of view). We first demonstrate controllability of the resulting system, and then describe optimal paths for the system.

The study of optimal paths for nonholonomic systems has been addressed by numerous researchers (a nice overview is given in [3]). Dubins [2] determined the shortest paths for a car-like robot than can only go forward. Reeds and Shepp extended this work and established the shortest length paths for a car-like robot that can move forward and backward [4]. Balkcom and Mason determined the time-optimal trajectories for a differential drive robot [1]. All of these results assume that the nonholonomic robot moves in the free space (without obstacles). These previous results do not address the case with sensing constraints on the robot. In this paper we address the combination of nonholonomic constraints and constraints imposed by the sensor. The latter essentially define a forbidden region in the configuration space of the system. We demonstrate that optimal paths for such a system consist of segments that are either straight lines in the plane or curves that saturate the sensor viewing angle.

### A. Problem definition

We make the usual assignment of body-attached frame to the robot, with origin at the midpoint between the two wheels,  $y$ -axis parallel to the axle, and the  $x$  axis pointing forward, parallel to the heading of the robot. The configuration of the robot can be represented by  $(x, y, \psi)^T$ , in which  $\psi$  is the angle from the world  $x$ -axis to the robot's  $x$ -axis.

The camera is positioned so that the optical center lies directly above the origin of the robot's local coordinate frame, and we denote the camera pan angle by  $\phi$ . We assume that the range of camera rotation is limited, such

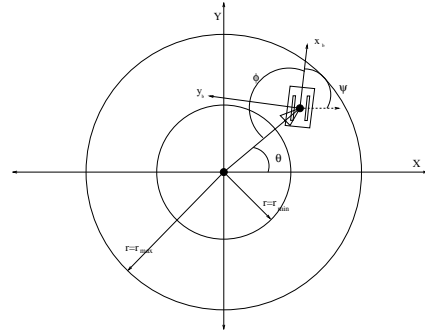

Fig. 1. Coordinate frame assignments for a differential drive robot with camera.

that  $\phi \in [\phi_1, \phi_2]$ . The camera will have finite range  $r_{\max}$ , beyond which it cannot detect the landmark. Thus, while navigating, the distance from the robot to the landmark must be no greater than  $r_{\max}$ . We also assume that the robot must maintain some minimum distance  $r_{\min}$  from the landmark (e.g., to avoid collision or to respect depth of field constraints). Without loss of generality, we place the (static) landmark at the origin of the world coordinate system. These conventions are illustrated in Figure 1. Given this formulation, the problem that we consider is that of finding minimal length paths from initial to goal position (without regard to the robot orientation) such that the following conditions are satisfied:

- 1) The camera is always pointing toward the landmark, i.e.

$$\psi + \phi = \pi + \tan^{-1} \frac{y}{x}. \quad (1)$$

- 2) The robot does not violate the constraints imposed by  $r_{\min}$  and  $r_{\max}$ , i.e., the robot does not leave the annulus

$$\Omega = \{(x, y) \mid r_{\min}^2 \leq (x^2 + y^2) \leq r_{\max}^2\}. \quad (2)$$

- 3) The constraints on camera motion are not violated, i.e.,

$$\phi \in [\phi_1, \phi_2]. \quad (3)$$

## II. T CURVES AND CONTROLLABILITY

In this section we give a constructive proof that the differential drive robot system is controllable under the visibility constraints described above. The proof proceeds

by constructing piecewise smooth paths consisting of path segments during which the camera pan angle is saturated either at its minimum or maximum value. We refer to a path segment with the pan angle saturated as a **T curve**, and we refer to a sequence of alternating T curves (i.e., the segments are saturated alternately at the minimum and maximum values for pan angle) as an **S curve**.

#### A. T curves

In the development that follows, it is convenient to express the robot configuration as  $(r, \theta, \psi)^T$  in which  $r, \theta$  are the polar coordinates

$$\theta = \tan^{-1} \frac{y}{x}, \quad r = \sqrt{x^2 + y^2}.$$

Consider a curve in the robot's workspace passing through the point  $(r_0, \theta_0)$ , such that corresponding robot path satisfies (1) for at all points. Since the robot's  $x$ -axis is tangent to the path, the constraint (1) effectively eliminates one degree of freedom of motion, leading to the following proposition, which is stated here without proof due to space limitations.

**Proposition 1:** For a fixed value of  $\phi$ , any robot path passing through the point  $(r_0, \theta_0)$  and satisfying (1) is given by

$$r = r_0 \exp \left\{ \frac{(\theta_0 - \theta)}{\tan \phi} \right\}. \quad (4)$$

If we evaluate (4) for  $\phi = \phi_1$  and for  $\phi = \phi_2$ , we obtain the two "extremal" feasible paths through the point  $(r_0, \theta_0)$ . The space between these two curves represents the set of possible directions of heading for the robot from a given point in the plane. Such a pair of curves can be constructed at each point in the plane and the robot can move along each such curve while respecting the camera constraints (1) and (3). Hence the curves can be thought of as latitudes and longitudes.

The paths that we describe below are constructed from curves that satisfy (4) evaluated at  $\phi_1$  or  $\phi_2$ , leading to the following two definitions, which are illustrated in Figure 2. A curve that satisfies (4) with  $\phi = \phi_1$  will be referred to as a **T1 curve**. Such a curve maintains a constant angle of  $\phi_1$  between the optical axis of the camera and the heading of the robot. A curve that satisfies (4) with  $\phi = \phi_2$  will be referred to as a **T2 curve**. Such a curve maintains a constant angle of  $\phi_2$  between the optical axis of the camera and the heading of the robot. When a **T curve** passes through a point then we add the label of the point as a subscript to the curve to denote that the curve is passing through the point. For example, **T1<sub>P</sub>** refers to a **T1 curve** passing through point P.

Refer to figure 3. We can see that  $T1_P$  and  $T2_P$  divide the plane around P into four disjoint regions. We have followed a nomenclature of naming those regions as shown in figure 3. If the camera is allowed to rotate in a closed interval  $[\phi_1, \phi_2]$ , the possible heading of the robot can only be in the region A or B. If the camera is only allowed to rotate in the closed interval  $[\phi_2, \phi_1 + \pi]$ , then the possible heading of the robot from P can only be in the region C or

D. Hence the **T curves** not only divide the plane around P into four disjoint regions, they also divide the space of all possible velocities of the robot into two mutually exclusive regimes.

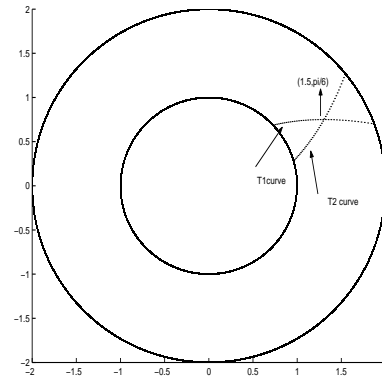

Fig. 2. A T1 and T2 curve passing through  $(r, \theta) = (1.5, \frac{\pi}{6})$  for  $\phi \in [-\frac{\pi}{6}, \frac{\pi}{6}]$ .

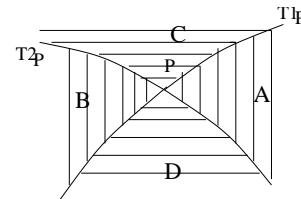

Fig. 3. State space division around P by T curves

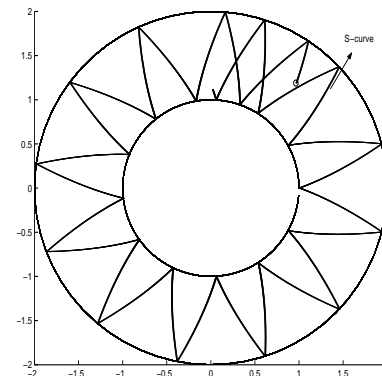

Fig. 4. An S curve for  $\phi \in [-\frac{\pi}{6}, \frac{\pi}{6}]$ .

#### B. S Curves

It is possible to concatenate a sequence of T-curves that remain inside the annulus given by (2) to create what we refer to as an **S curve**. The procedure for doing so is iterative, and the  $i^{th}$  segment in the S curve consists of a T1 segment followed by a T2 segment. There are four possible strategies, corresponding to whether we increase or decrease  $\theta$  as we build the S curve, and to whether we begin with a T1 or T2 curve. Of these four strategies, only two generate unique S curves (the other two strategies

merely traverse the curves in the opposite sense). Thus, for any  $q = (r, \theta, \psi)^T$ , there exist exactly two unique S curves. If we begin with a T2 curve and use increasing values of  $\theta$ , the procedure begins by tracing the T2 curve through  $q_0$ , until  $r = r_{\max}$ . From this point, trace a T1 curve until  $r = r_{\min}$ . From this point, trace a T2 curve until  $r = r_{\max}$ , etc. Such an S curve is shown in Figure 4, with  $\phi_1 = -\pi/6$  and  $\phi_2 = \pi/6$ .

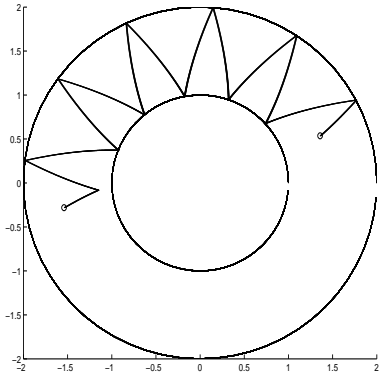

Fig. 5. A possible path from  $q_i$  to  $q_f$  for the differential drive robot.

**Proposition 2:** For two feasible configurations,  $q_i$  and  $q_f$  satisfying the visibility constraint (1) and respecting the constraint on camera motion (3). Hence the system is controllable.

The proof is constructive and not difficult. One essentially builds a path by following an appropriate set of S curves. As a consequence of this proposition, the differential drive robot and camera system is controllable, and thus there exists a path between any two points in  $\Omega$ . Hence there exists a path that has minimum length (since  $\Omega$  is closed). With the above tools in hand we move on to derive paths, optimal in sense of length between any two points in  $\Omega$ .

### III. PROPERTIES OF OPTIMAL PATHS

In the following, we derive minimal length paths between two points in the plane for the DDR. These paths are not necessarily minimal with respect to distance in the configuration space; rather, they are paths whose projection onto the plane are minimal. We denote continuous paths as  $C^0$  paths and continuously differentiable paths as  $C^1$  paths.

#### A. S-set

The S-set of a point P, located in  $\Omega$ , is the set of points which can be reached on a straight line path from P. The derivation of the S-set for a point P is given in the appendix. The S-set for P is illustrated in figure 6.

#### B. Type A and Type B points

**Type A:** A nondifferentiable point, P, on the optimal path is said to be of Type A if it represents a transition from a T1 curve to a T2 curve. This is illustrated in figure 7.

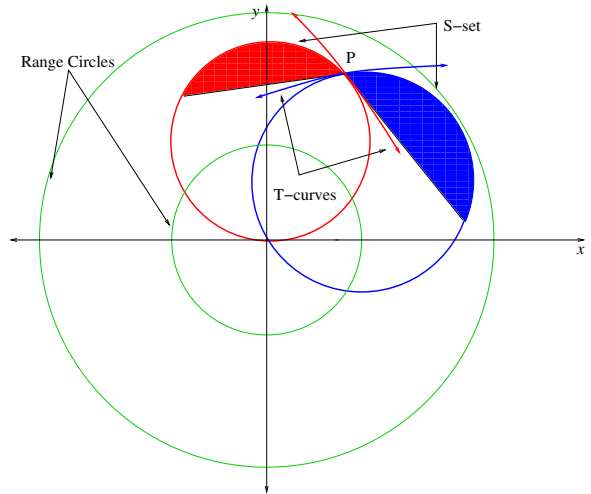

Fig. 6. S-set

**Type B:** A nondifferentiable point, P, on the optimal path is said to be of Type B if it represents a transition from a T2 curve to a T1 curve. This is illustrated in figure 7.

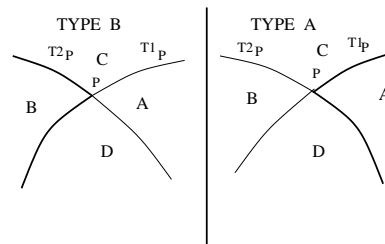

Fig. 7. Type of nondifferentiable points on the path

The optimal paths satisfy certain properties due to the kinematic constraints on the DDR. We present some propositions that will be useful in deriving the optimal paths. Again, due to space limitations the proofs are omitted.

**Proposition 4:** If P and Q are two points lying on the same T curve, the only smooth path possible from P to Q, respecting the camera constraints, is the direct path from P to Q lying on the T-curve.

**Proposition 5:** If Q lies in region C or D, then no  $C^1$  path exists between P and Q.

**Proposition 6:** If optimal path is smooth in the neighbourhood of a point P, then P must lie on a straight line or a T-curve.

**Proposition 7:** For  $C^0$  paths to be optimal the nondifferentiable points on the path can only be of Type A or Type B.

### IV. THE LANGUAGE OF OPTIMAL PATHS

From the above propositions, we conclude the optimal paths include only segments that are T-curves and straight lines (denoted respectively by T1, T2 and SL). In the case of a nonsmooth continuous path, the nondifferentiable points can be only of Type A or Type B. We represent

a path by a string (or a *word*) of the form  $X_1 - X_2 * X_3 \dots X_n$ , where each  $X_i$  is one of T1, T2 or S, and where the symbol - denotes a smooth transition between segments and the symbol \* denotes a nonsmooth transition. For example,  $SL - T1$  implies that SL is tangent to T1 at the point of contact, whereas  $SL * T1$  denotes that SL is not tangent to T1 at the point of contact.

Due to the kinematic constraints of the DDR and the properties of optimal paths, only a subset of possible words are included in the language of optimal paths. The following proposition makes this set explicit.

**Proposition 8:** If a straight line is present in the optimal path then the only words possible are SL-T1, T1-SL, SL-T2, T2-SL, T1-SL-T2 and T2-SL-T1.

From the above proposition we can conclude that the set of acceptable words are SL, T1, T2, SL-T1, T1-SL, SL-T2, T2-S, T1-SL-T2, T2-SL-T1,  $T1 * T2 * T1 * T2 \dots$  and  $T2 * T1 * T2 * T1 \dots$ . The last two words can consist of any number of repetitions as long as the transition from one T curve to another T curve occurs through a Type A or Type B point.

## V. CONSTRUCTING OPTIMAL PATHS

For a starting point  $P$  in the plane, the words in the language of optimal paths induce a partition of the plane into regions such that a specific word corresponds to the optimal path to any goal point  $G$  in a region. This partition is illustrated in figure 8, in which the regions are given labels that are used in the discussion below. We now enumerate the possible words and identify the regions in which each applies.

### A. $SL$ region(Regions I and I')

The S-set of the point  $P$  gives the region consisting of points that are reachable by SL. The S-set of  $P$  consist of sector of the circles.

### B. $T$ region(T1, T2 curves)

$T1_P$  and  $T2_P$  are the curves that are obtained by following the words T1 and T2 from  $P$ .

### C. $SL-T1$ region(Region II)

Consider a straight line from  $P$  to a point  $Q$  that lies at the boundary of the S-set. It can be shown that the segment  $PQ$  is tangential to  $T1_Q$ . All points lying on  $T1_Q$  are reachable by the word SL-T1. The loci of points on  $T1_Q$  obtained by moving  $Q$  over the boundary of the S-set of  $P$  forms Region II. Region II is enclosed by the curves  $T1_P$ , arc  $PP'$  and  $T1_{P'}$ .

### D. $SL-T2$ region(Region II')

Region II' is obtained in manner similar to that used to derive Region II. Region II' is bounded by  $T2_P$ , arc  $PP''$  and  $T2_{P''}$ .

### E. $T2-SL$ region(Region III)

If the optimal path from  $P$  to  $G$  is of the form  $T2 - SL$ , then  $P$  lies in Region II' with respect to  $G$ . Hence the Region III of  $P$  consists of all those points  $G$  for which  $P$  belongs to Region II' of  $G$ . The region is bounded by  $T2_{P'}$ ,  $T2_P$  and the chord  $PP'$ .

### F. $T1-SL$ region(Region III')

Region III' is obtained in manner similar to that used to derive Region III. Region III' is bounded by  $T1_P$ , arc  $PP''$  and  $T1_{P''}$ .

### G. $T2-SL-T1$ region(Region IV)

Consider a point  $G$  in Region IV. The optimal path from  $P$  to  $G$  consists of  $T2_P$ ,  $T1_G$  and a bitangent to both the curves. Region IV is bounded by  $T1'_P$  and  $T2'_P$ .

### H. $T1-SL-T2$ region(Region IV')

The optimal path from  $P$  to a point  $G$  lying in Region IV' consists of  $T1_P$ ,  $T2_G$  and a bitangent to both curves. Region IV' is bounded by  $T1''_P$  and  $T2''_P$ .

### I. $T1 * T2 * T1 \dots$ region(Region V and Region VI)

The points reachable by using the word  $T1 * T2 * T1 * T2 \dots$  lie in Region V and Region VI. This is due to the underlying fact that the point on the optimal path at which the transition  $T1 * T2$  or  $T2 * T1$  takes place must be of Type A or Type B.

### J. $T2 * T1 * T2 \dots$ region(Region V and Region VI)

The analysis for  $T1 * T2 * T1 \dots$  also holds true for this region and hence the reachable set of points from  $P$  remains the same.

The above analysis provides an exhaustive enumeration of the possible cases. The only regions for which more than one word is possible are Region V and Region VI. Further analysis about Region V and VI, details of which are not provided here, demonstrate that the words of the optimal paths in Regions V and VI depend on the numerical values of  $\phi_1$  and  $\phi_2$ . The results are tabulated in I. The analysis for the optimal paths required to move from an initial point  $P$  to a final point  $G$  in the workspace is given in figure 8 and table II.

TABLE I  
WORDS FOR REGIONS V AND VI

Cases	Region V	Region VI
$\phi_1, \phi_2 \in [0, \frac{\pi}{2})$	$T2_P - T1_G$	$T1_P - T2_G$
$\phi_1 \in [0, \frac{\pi}{2}), \phi_2 \in (\frac{\pi}{2}, \pi)$ $\phi_1 + \phi_2 \leq \pi$	$T2_P - T1_G$	$T1_P - T2_G$
$\phi_1 \in [0, \frac{\pi}{2}), \phi_2 \in (\frac{\pi}{2}, \pi)$ $\phi_1 + \phi_2 > \pi$	$T1_P - T2_G$	$T2_P - T1_G$
$\phi_1, \phi_2 \in (\frac{\pi}{2}, \pi)$	$T1_P - T2_G$	$T2_P - T1_G$

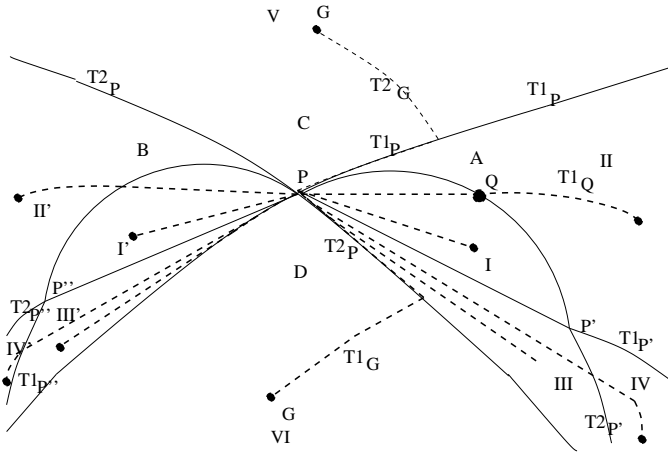

Fig. 8. Optimal paths for the case in which velocity vectors from P are allowed in regions A and B but forbidden in regions C and D

TABLE II

TYPES OF OPTIMAL PATHS ACCORDING TO REGIONS: REGIONS A AND B ALLOWED,  $\phi_2 > \phi_1$

Region	Subregion	Type of paths
A	I	SL
B	I'	SL
A	II	$T2_P - SL$
B	II'	$T1_P - SL$
A	III	$SL - T1_G$
B	III'	$SL - T2_G$
A	IV	$T2_P - SL - T1_G$
B	IV'	$T1_P - SL - T2_G$
C, D	V, VI	Refer Table I

## VI. COMPLEMENTARY CASE

Next we consider the case in which the DDR is allowed to move in regions C and D, and forbidden to move in A and B. To analyze this case let us refer to figure 9. We denote the allowed interval of camera movement as  $(\phi_{1N}, \phi_{2N})$  where  $\phi_{1N} = \phi_1$  and  $\phi_{2N} > \phi_{1N}$ . The regions of allowed movement of the DDR are A and B (C and D are forbidden). Now let us increase  $\phi_{2N}$ . This results in a rotation of the  $T_{2P}$  curve around P. Consider the case when  $\phi_{2N} = \pi$ . The S-set is a sector of a circle tangent to  $T_{2P}$  (which is a radial line) and passing through the origin. Hence the S-set becomes a sector of a circle of radius  $\infty$ , which is a region bounded by the rays PL and PM. Hence the region IV and III vanish. Now consider the region B (figure 9(b)) as we increase  $\phi_{2N}$  to  $\pi$ . It looks as in figure 9(c), since regions II and IV vanish. The case considered in this section can be analyzed as shown in figure 9 leading to figure 9(d), which shows the final structure of the regions. The optimal paths in regions A and B are also shown in figure 9(d) by the dashed lines.

The analysis for the optimal paths required to move from an initial point P to a final point G in the workspace is given in figure 10 and table III.

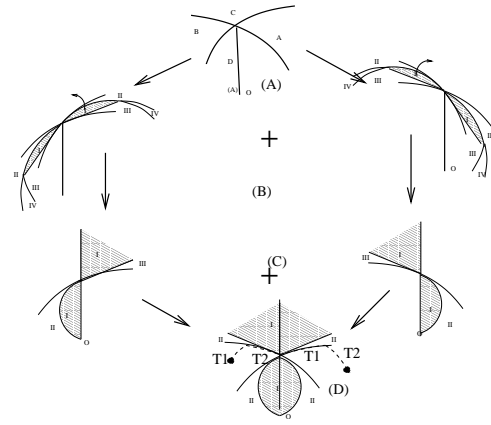

Fig. 9. Complementary case

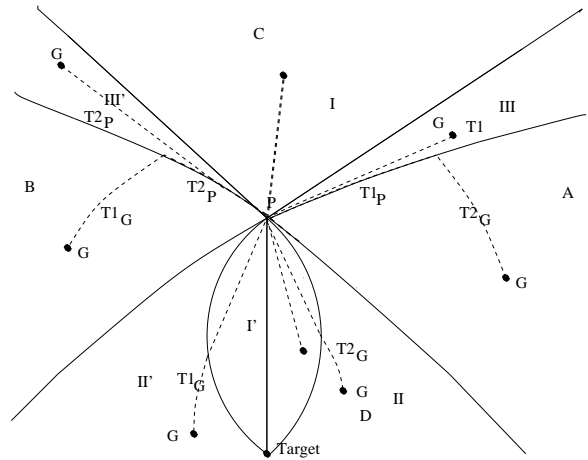

Fig. 10. Optimal paths for the case in which velocity vectors from P are allowed in regions C and D but forbidden in regions A and B

## VII. CONCLUSION AND FUTURE WORK

In this paper we have described minimal length paths for a differential drive robot that maintains visibility of a landmark while moving between any two locations. We have shown that the optimal paths are composed of straight lines and curves,  $T1$  and  $T2$ . The analysis we have given provides optimal paths for an infinite range sensor, i.e., we did not take range constraints as given in (2) into account. Future research will focus in finding the optimal paths for finite sensor range. Another direction of future research incorporates the above results to define the necessary and sufficient conditions to guarantee the existence of a free path for a polygonal differential drive robot with limited perception to maintain visibility of a landmark throughout the whole path.

## REFERENCES

- [1] D. J. Balkcom and M. T. Mason. Time optimal trajectories for differential drive vehicles. *International Journal of Robotics Research*, 21(3):199–217, March 2002.
- [2] L.E. Dubins. On curves of minimal length with a constraint on average curvature and with prescribed initial and terminal position and tangents. *American J. of Mathematics*, 79:497–516, 1957.
- [3] J.-P. Laumond. *Robot motion planning and control*. Springer, 1998.

TABLE III

TYPES OF OPTIMAL PATHS ACCORDING TO REGIONS: REGIONS C AND D ALLOWED (COMPLEMENTARY CASE),  $\phi_2 > \phi_1$

Region	Subregion	Type of paths
C	I	SL
C	III'	$T2_P - SL$
C	III	$T1_P - SL$
D	I'	SL
D	II'	$SL - T1_G$
D	II	$SL - T2_G$
A	unique	$T2_P - T1_G$
B	unique	$T1_P - T2_G$

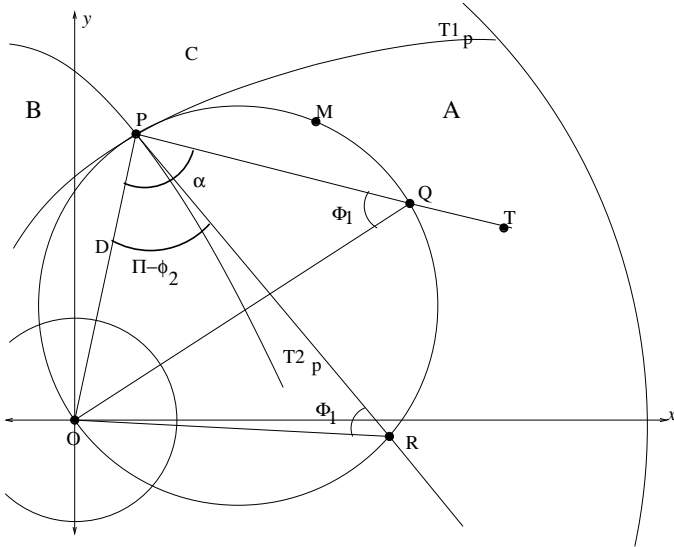

Fig. 11. Construction of S-set

- [4] J. A. Reeds and L. A. Shepp. Optimal paths for a car that goes both forwards and backwards. *Pacific Journal of Mathematics*, 145(2):367–393, 1990.

#### APPENDIX

##### DERIVATION OF S-SET

Refer to figure 11. Consider the line  $PT$  in region A such that  $\angle OPQ = \alpha$ . If the end point  $Q$  on  $PT$  satisfies the constraint,  $\angle OQP = \phi_1$ , the robot can move on a straight line path from  $P$  to anywhere in between  $P$  and  $Q$ , on the line  $PT$ , without violating the camera constraints. Since chord of a circle subtends same angle on any point on the arc, the loci of point  $Q$  is a circle circumscribing  $\triangle PQO$ . Due to the camera constraints, the heading direction of the robot from  $P$  is limited by the line  $PR$ , satisfying  $\angle OPR = \pi - \phi_2$ . The S-set in region I is given by the area enclosed by the arc  $PMR$ . Another region of the same kind will exist in region B.