

Is the Solar System Stable?

Jürgen Moser

This article is based on the first of three Pauli lectures, given at the Eidgenössische Technische Hochschule in Zurich in January, 1975. It originally appeared in German in the *Neue Zürcher Zeitung* of May 14, 1975.

The Stability Problem

The stability problem of classical mechanics, that is, the question as to the stability of the solar system, has fascinated astronomers and mathematicians for centuries. It is simply the question of deciding whether the planetary system in the distant future will keep the same form as it now has or whether after a long time perhaps one or another of the planets might leave the solar system or whether collisions might even lead to a catastrophic change. Since Newton, that is for about 300 years, one has known the laws which govern planetary motion. To a first approximation, the planets move in elliptical orbits in which the sun is located at one of the foci of the ellipse. This is however only a crude approximation to the true motion. The forces between the individual planets cause perturbations so that the form of these elliptical orbits very slowly but steadily changes. The description of these changes, the so-called *secular perturbations of the elliptical orbits*, is the problem that is treated by classical perturbation theory. Now it is conceivable that the relatively weak forces between the planets after a sufficiently long time would so greatly change the present orbits that a planet might be thrown out of the system or that a collision might occur. For example, one can imagine that the eccentricity of a planet might continually increase until its perihelion came so close to the sun that it would meet with misfortune. Although such an eventuality does not agree with our observations over the last millenia, it is something altogether different to *prove mathematically* from the equations of motion that it cannot occur.

As a matter of fact the literature already contains a considerable number of stability proofs. About 100 years after the publication of Newton's *Principia*, Lagrange gave his famous stability proof for the solar system. Further proofs of this type were given by Laplace and Poisson, and one might well ask why the question is again being raised 200 years later. In general one proof is sufficient and the carrying out of several proofs tends to make a critical listener rather suspicious. Actually it is a question here of approximations of varying degrees of accuracy in which the perturbing forces are taken into account only to the first or second powers of the planetary masses. In practice this means that the changes in the elliptical orbits will require a substantial amount of time before they become

noticeable. Sommerfeld speaks in his book with F. Klein very tersely of Laplace's "mock proof" (*Scheinbeweis*), of the stability of the planetary system. How justified these approximations are remains to be seen. When one restricts consideration to a few decades or centuries these stability proofs certainly give the right conclusion, but from this one naturally cannot draw any conclusions about motion in *many millions of years*. Formerly one was primarily interested less in long range predictions than in the practical computation of the positions of the planets, the so-called ephemerides – a question that was of interest already to the Babylonians. Perturbation theory is in fact an outgrowth of the necessity to determine the orbits with ever greater accuracy. This problem can be solved today, but in what is for the theoretician a rather disappointing way. With modern calculating machines, one is now able to compute directly results even more accurately than those provided by perturbation theory. Today the ephemerides of the Nautical Almanac in Washington are computed in this way.

But the mathematical problem only begins here. It is a tried and true technique of mathematics to extract the essential properties of a problem and to idealize it. We deal not with the planets of the solar system, which are after all extended masses, and all kinds of forces are disregarded, such as, for example, the solar wind and relativistic effects. Instead we consider an idealized problem and study n *mass points* which move in 3-dimensional space according to Newton's laws. For the most part one assumes further that $n - 1$ of these fictitious mass points have *very small masses* compared to the remaining one, which plays the role of the sun. Furthermore, we do not ask for the development of the motion for a limited time but *for all eternity*. This is now a purely mathematical problem, the solution of which has a rather limited meaning for the real world, but which entails, by virtue of the demand for a description for all time, very astonishing subtleties. Even this idealized mathematical problem was formulated at least a 100 years ago and is rather vaguely known as the n body problem. In the previous century this problem was of the greatest interest and, as we shall now see, Dirichlet, who today is best known for his monumental works in number theory, and Weierstrass, the function theorist, as well as Poincaré, a universal mathematician, all played essential roles in the treatment of this problem. Thus it is a matter of describing the behavior of the secular perturbations over long time intervals and even for all time. Can changes in the shape and position of the orbits completely alter the configuration of the planetary system? Lagrange proved in connection with his stability proof that these perturbations are subject to

periodic oscillations and thus do not increase without bound. The periods of these oscillations are relatively long, requiring from 5×10^4 to 2×10^6 years. But one must further mention that one is dealing here with an approximation and that in a certain sense this statement can be regarded as a refinement of the age-old description of the planetary orbits by epicycles.

However, what will happen in time intervals of *several million years*? It is a question here of a resonance problem in which the motions of the eight planets play the role of oscillators. Of course, resonance occurs when one deals with a system with a frequency which coincides with one of the eigenfrequencies of the system or an integer multiple of one. The simplest resonance phenomenon is that of pumping a swing. With relatively small forces which are carried out periodically at the frequency of the swing one can increase the amplitude of the swing as high as one wants and can even cause the swing to overturn. In the case of the solar system, such phenomena also play a major role. Indeed, because there is no friction to speak of, any oscillation once established is never damped out. This is the reason why the resonance effects are so subtle for undamped systems in contrast to all everyday physical experiments — or swings. In our solar system there are a great many resonances. For example, it is known that Jupiter and Saturn have a frequency ratio of about $5/2$ so that after 5 Saturn years Jupiter has gone through exactly 2 if its years and the forces after this period continue to act in the same direction. This indeed has a strong effect on the orbit of Jupiter, a perturbation whose period to a first approximation is about 900 years.

In reality, however, one must expect such resonances for all rational frequency ratios and even those in which a linear combination of the frequencies with integer coefficients vanishes (commensurable frequencies). This is naturally utterly absurd, for in fact the rational numbers are dense, and from a physical point of view

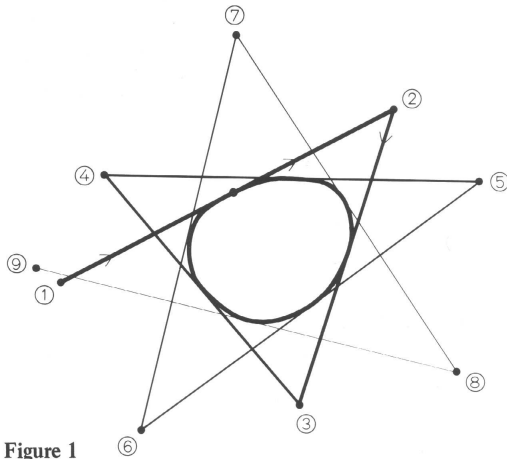

Figure 1

one can not distinguish between rational and irrational frequencies. On the other hand, the mathematical development definitely requires such a distinction, and we arrive at a paradoxical situation. The equations of motion for the n body problem are very easy to write down but impossible to comprehend intuitively. Therefore it may be useful to describe a very simple geometrical problem that actually contains some of the difficulties of the n body problem and may serve as a crude model for planetary motion (Figure 1). We consider an oval in the plane and define the “orbital motion” in the exterior of the oval as follows. We draw from a point 1 in the exterior one of two tangents to the oval and prolong the tangent to the point 2 which has the same distance from the point of tangency as 1. From 2 we lay out the next tangent to the oval up to point 3, which again has the same distance from the point of tangency. Continuing in this manner we obtain the “orbit” through the point 1. Can this sequence of points be unbounded? This would be the analogue of the stability problem. Although this problem seems quite elementary it is actually very difficult. One can show that for curves which are smooth enough (admitting 5 derivatives) and have positive curvature the orbits are always bounded, i.e. we have stability.

It is remarkable that in this simple problem the smoothness of the bounding curve should play a role. What happens if corners are admitted? The simplest cases are polygons. Actually the mapping is not continuous in this case but the problem of stability remains clearly meaningful. For general polygons, however, it remains an open question whether the orbits are bounded or not. But there are two special cases which can be fully treated:

- 1) When the oval degenerates into a 2-gon every orbit goes to infinity along a pair of straight lines (Fig. 2).
- 2) When the oval is a triangle then all orbits are closed but they have different periods. Points belonging to orbits of the same period form hexagons and triangles which constitute an interesting tessellation of the plane. Points in the hexagons have periods 3, 9, 15, 21, . . . , in general $3(2j - 1)$, $j = 1, 2, \dots$. Those of the triangles have period 12, 24, 36, . . . , in general $12j$, $j = 2, 3, \dots$ (Fig. 3). For a square the problem can also easily be handled but even for a general quadrilateral the above question is open.

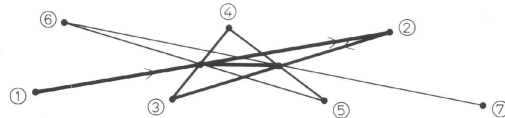

Figure 2

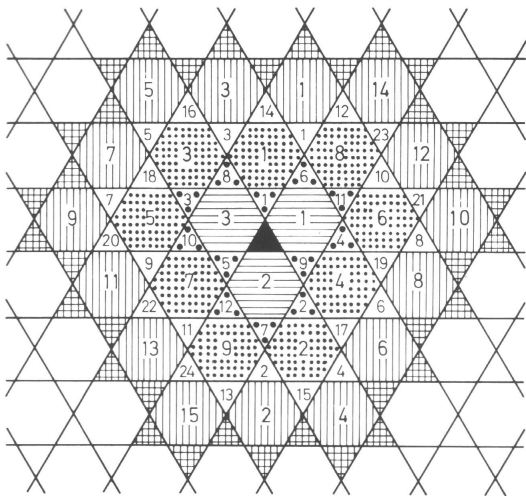

Figure 3

The Prize Question

We return to planetary motion and to the mathematical formulation of the problem and its solution. One attempts to describe the coordinates of the secular perturbations analytically using generalized *Fourier Series*. These are series the terms of which are of the form

$$A_j \cos (j_1 \omega_1 + \dots + j_s \omega_s) t \\ + B_j \sin (j_1 \omega_1 + \dots + j_s \omega_s) t$$

with certain frequencies $\omega_1, \dots, \omega_s$ and combination frequencies $j_1 \omega_1 + \dots + j_s \omega_s$. This point of view is not far removed from the epicycle theory, but it is mathematically more precise. Such functions are today known as quasi-periodic functions. In fact various mathematicians succeeded, as for example Weierstrass, in obtaining such series developments *formally*, assuming that $\omega_1, \dots, \omega_s$ are incommensurable (that is their ratios are irrational). But these series may not converge and therefore their usefulness was very much in question. On the other hand, when they converge they describe the small oscillations in the variations of the ellipse. Changes of elements that are thus described remain forever within given bounds.

The mathematical problem can be described as follows: "For an arbitrary system of mass points which attract each other according to Newton's laws, assuming that no two points ever collide, give the coordinates of the individual points for all time as the sum of a uniformly convergent series whose terms are made up of known functions"¹. This is the word for word translation of a prize question which King Oscar II of Sweden proposed in 1885, that is, 90 years ago. The prize was awarded to H. Poincaré, although he did not

in fact solve the problem. His great work actually indicated that such series developments, contrary to all expectations, diverge and thus do not exist. One will be even more surprised to hear that in 1963 an excellent young mathematician in his middle twenties succeeded in solving this problem and in proving the existence of such solutions with complete rigor, at least in the case of the 3 body problem! This mathematician, V. I. Arnold, was a student of Kolmogorov, who a few years before had laid the cornerstone of the proof. More precisely, the breakthrough was based, of course, on the work of many others, and essentially the ideas go all the way back to Poincaré's results.

In the 1940's Siegel solved the first problem of this type. His formulation of the question was, however, more idealized and was not really applicable to mechanical problems. In 1954 Kolmogorov indicated that, for certain mechanical systems, in some sense the *majority* of solutions are quasi-periodic. He indicated a possible method of solution but the actual proof was first provided by Arnold 8 years later, and, in a special case, by the author. In accordance with the modern usage this theory became known by the acronym KAM. The principle result of this theory guaranteed the existence of such quasi-periodic solutions for certain classes of differential equations which included the n body problem. The series developments in question turn out to be convergent for certain choices of the frequencies but are meaningless for other frequencies. This last result was already shown by Poincaré. The orbits which admit such a representation are precisely those for which no resonance occurs. However, since such resonance-free orbits can lie arbitrarily near to the others, it is entirely possible that an arbitrarily small perturbation in the initial values will change a quasi-periodic stable orbit to an unstable one. One can show, however, that the unstable orbits are much rarer, or, as one would say more technically, in phase space have relatively small measure. This means that one is led to a *new concept of stability* in which the restriction applies only to the *majority* of certain orbits. Whether the relatively rarer unstable exceptional orbits actually exist is still an open problem. We must say at the outset — and it will be shown in what follows — that the weakened concept of stability is very meaningful and satisfactory for the physical applications.

New Applications

But in what does the great progress lie? If the determination of the orbits can be handled very well with computing machines, such a proof seems *superfluous* and at very least *historically too late*. To this one can make the following reply:

1. The stability of undamped systems *for all time* can not in principle be decided by finite calculations and

lies therefore beyond the range of calculating machines.

2. What is more important, however, is that such a result which, by the way, is of the greatest interest in itself from the point of view of mathematics, is also of essential importance to theoretical researches in *statistical mechanics*. The development of statistical mechanics had led to the expectation that most mechanical systems, at least when they are made of sufficiently many particles, are ergodic, that is, after a sufficiently long time their behavior is entirely independent of the initial conditions. This stands, however, in the most striking contrast to stability. In fact, physicists have, beginning with this point of view, in the past century attempted to show that almost all mechanical systems display this unstable behavior provided only that one waits long enough. That this is *not* so for many realistic systems is now, through the work of the last decade, proved once and for all.
3. There is finally a third ground which appears to be more or less coincidental: the mathematical theorems of KAM deal not only with the planetary system but also with general Hamiltonian systems (thus, systems which describe undamped processes of motion) and can therefore be applied to many *other problems*. This is precisely the advantage of a general mathematical formulation. One of these applications is the stability problem of proton accelerators, which since the 1950's have been built in every greater numbers and greater size. The purpose of these machines is to accelerate electrons or protons to extremely high velocities and then to shoot them at a target in order to observe the results of the consequent disintegration, namely, new elementary particles. The greater the energy of the particle is, the more interesting the resulting observations will be. In order to achieve these high velocities, the protons are accelerated in a circular channel more and more until the particles reach a velocity near the velocity of light. These channels, in the case of the proton synchrotron at CERN in Geneva, have a circumference of over 600 meters; and air is pumped out of them in order to create a high vacuum and avoid collisions with gas molecules. A magnetic field is created by a series of magnets, and this field holds the particles in a nearly circular path. This leads to a stability problem because the magnetic field must be constructed in such a way that the protons do not deviate too far from an ideal circular path and thereby lose their energy on the walls of the chamber. In the process, the particles run around the vacuum chamber millions of times.

The question of stability is an essential point in the construction of these accelerators. Although one was at first content to make experiments with calculating

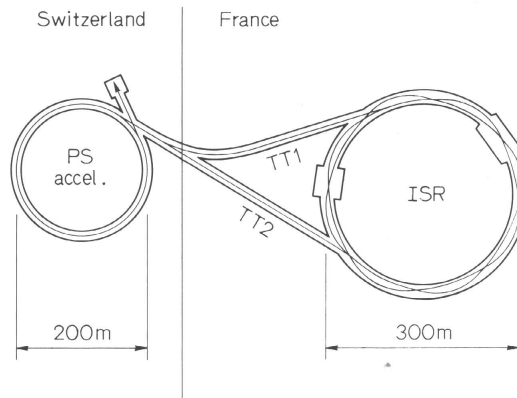

Figure 4 a. Cross-section of the vacuum chamber at the position of the beam inflector, with indication of the stacking process

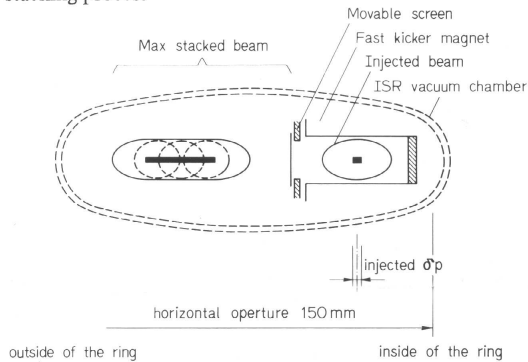

Figure 4 b. Layout of the intersecting storage rings (ISR)

machines, it soon became clear that after a few iterations the unavoidable computational error got out of hand and it became impossible to follow or to predict the paths. One needed *theoretical results* which showed that one could guarantee stability in such a system over a very long time interval, and that is precisely the significance of the theory we are discussing. The latest stage in this development is represented by the so-called *storage rings* of which one has been operating at CERN since 1971 (Figure 4). Roughly speaking, it is a matter of accelerating protons in two circular channels in *opposite directions* and then aiming the beams at one another. In this way the available energy is not only doubled, as one would expect, but, because of relativistic effects, is increased by the square. In order to achieve the motion of protons in opposite directions, one connects such a storage ring (ISR – intersecting storage ring) to the proton synchrotron and introduces bunches of protons alternately in one or the other direction into the storage ring. There they are stored, a process which can last from 3 to 11 hours, until they are made to collide.

The construction of this machine presents *unbelievable technical difficulties* and demands unheard-of precision which would make even Swiss watch manufacturers blanch. There is an obvious comparison to be made here, which is of importance to our stability problem: During the storage process the proton packets must orbit 10^{10} to 10^{11} times around the circular path and in the course of this time be contained within a tunnel that is 16 by 5.2 centimeters. When one equates a circuit of the protons in the storage ring with a year in the astronomical problem, then the above number represents a time which surpasses the age of the earth. That is, one can follow the protons for a longer time, in this analogy, than the solar system has existed in its present form. In addition to this, the experimental physicist or technician can alter the conditions and the parameters at will. We discuss this example here because it requires stability over time intervals which exceed anything that was dreamed of in astronomy 100 years ago and therefore in a certain sense justifies the idealized stability question concerning infinite time intervals, if indeed such justification were necessary. When one applies the results of KAM theory in this situation one finds that the majority of accelerated protons are conserved within the circle of the storage rings but that the relatively rare exceptional orbits lead to a slow and very slight loss in the proton rays. Such losses are in any case unavoidable and are also observed. Whether these exceptional orbits can be considered to be responsible for this loss must be regarded as still unresolved in view of the fact that many additional forces and effects which affect the particles and may deflect them have been neglected. Such applications can provide a strong stimulus to mathematical research. One must certainly ask how it is that this age-old stability problem, just when it is losing its interest for astronomers, has suddenly been solved. One can well hypothesize that the development of proton accelerators has influenced the rebirth of interest in this question.

Stability of Periodic Orbits

We wish to describe another resonance phenomenon, which enters both in astronomy and in high energy physics. It is the question of the stability of *periodic orbits*, that is, of those solutions which after a certain time return to their initial configuration. One asks for conditions under which all orbits whose initial conditions lie near the periodic orbit remain for all time near the periodic orbit. Such orbits are called stable. Only such stable orbits are normally observable. The best example is the circular orbit in a storage ring described above. Small perturbations should not lead to large deviations. In order to determine whether these circular orbits are stable, one must use the so-called betatron frequencies ω_r , ω_z and the orbital frequency ω_o which belong to the oscillations of the linearized system. The theory shows that in general nonlinear resonance or instability will occur when the frequencies satisfy a relation

$$n\omega_r + m\omega_z = p\omega_o$$

with whole numbers n , m , p for which $|n| + |m| \leq 4$; such relations with $|n| + |m| > 4$, on the other hand, are harmless. Experiments show that in fact in the first case a loss in the beam is observed but in the second case this loss is negligible. Loosely speaking, resonances of order less than or equal to 4 are in general dangerous, whereas those of order greater than 4 are harmless.

An analogous phenomenon occurs in astronomy. As is well known, in addition to the major planets there are *many of thousands of asteroids* circling the sun; their orbits are primarily between those of Mars and Jupiter. Their masses are minuscule and therefore have no influence on the planets. On the other hand, the asteroids are very substantially perturbed by Jupiter. Evidence for

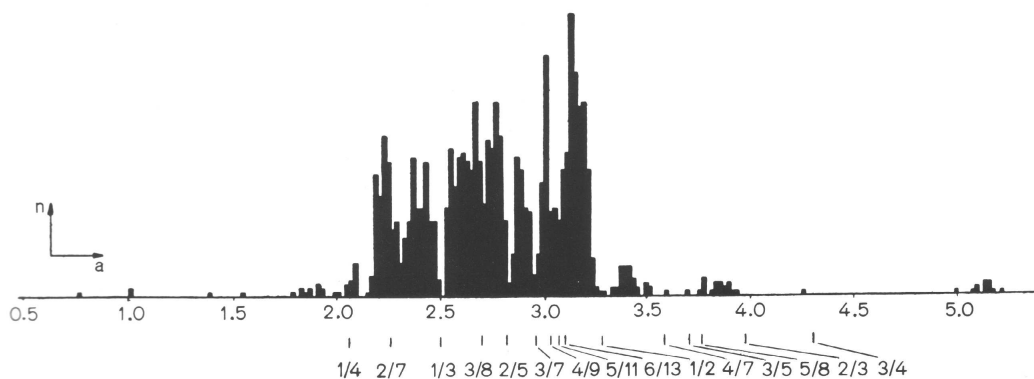

Fig. 5. The number of asteroids as a function of the semi-major axis a . The a -values corresponding to certain fractions of Jupiter's period are marked below. Some of these 'resonances' have produced gaps in the asteroid distribution.

this is an observation due to Kirkwood. He remarked that the frequencies of the asteroids are not uniformly distributed over an interval but that there are certain gaps, the so-called Kirkwood gaps, to be observed (Figure 5). One can consider this situation to be analogous to the gaps in the rings of Saturn, which in fact present a similar phenomenon. If the mean motion of the asteroids is denoted by ω_a and that of Jupiter by ω_j then the most pronounced gaps are given by the formula

$$\frac{\omega_j}{\omega_a} = \frac{n}{m} \quad |n - m| = 1, 2, 3, 4$$

and this means that it is a matter of resonances of order ≤ 4 . It remains to characterize the periodic orbits whose stability corresponds to the above conditions. One imagines Jupiter on an exactly circular orbit and lets the asteroids move on a nearly circular orbit in the same plane in such a way that the configuration, that is, the triangle formed by the sun, Jupiter, and asteroid returns to its original position after a certain period of time. Such periodic orbits were already derived by Poincaré. The orbits for which the resonance given above does not occur are stable, so that the explanation is obvious: the gaps correspond to unstable orbits. Although these are only crude approximations to the actual situation, they nonetheless successfully reflect the phenomenon of gaps. The mathematical explanation of this phenomenon is given rigorously by the KAM theory, although an essential idea can already be found in the work of Birkhoff, who continued Poincaré's work.

Historical Remarks

The following historical sketch illuminates the stability problem and its very dramatic development. These remarks were stimulated by the fortunate circumstance that the letters of Weierstrass to Sonya Kowalevsky were published a short time ago. These letters contain much interesting material on our subject which otherwise is very little known, even to mathematicians. Weierstrass played an absolutely central role in the mathematical life of the second half of the 19th century, and mathematicians from all over the world came to Berlin to hear his lectures. His principal interest and his life's work was function theory, but he also had a serious interest in astronomy and gave a seminar on perturbation theory in astronomy in 1880/1881. His ideas on this subject, and above all on the stability problem, were described in several letters to Sonya Kowalevsky. In view of the fact that Weierstrass published his results only very reluctantly and only after extensive and thorough — going revision, these informal communications are particularly valuable.

Sonya Kowalevsky came to Berlin from Russia to study mathematics in a truly adventurous way as a 20 year old student. It was certainly not customary to

have female students there, and she was barred from lectures, as a result of which Weierstrass gave her private instruction. From this developed a close friendship which endured until the end of Kowalevsky's life. Moreover, Kowalevsky developed into a well-known and celebrated mathematician, and was professor of mathematics in Stockholm, although she unfortunately reached this position only two years before her untimely death at the age of 41. In addition to personal communications, Weierstrass' letters to Sonya Kowalevsky contain a large number of mathematical ideas and proposals to his student giving a valuable insight into his manner of thinking.² However, one also finds very specific indications, as for example in the letter of 15 August 1878, that already at that time he was in possession of the formal series developments for quasi-periodic solutions of the n body problem, and was occupied with the question of their convergence. After this, there can remain no doubt that Weierstrass was on the track of exactly the same problem which has now been finally solved.

Why was Weierstrass so confident that his series representations actually converged? This is also known. Dirichlet, who was Gauss' successor in Göttingen, had already told his student Kronecker in the year 1858 that he had discovered an entirely new general method for dealing with and solving problems of mechanics. Dirichlet died the following year without leaving behind anything written about his discoveries, but Kronecker communicated Dirichlet's remarks to the mathematical world, which sought to recover this lost idea. Nowadays one connects the name of Dirichlet principally with number theory, which was indeed his main interest, while his works in mathematical physics are less well known. These include the foundations of the theory of Fourier series, stability figures of rotating fluids, hydrodynamical works, stability criteria for equilibrium, and others. Because Dirichlet's publications were known for the absolute rigor of their methods and their proofs, there was little doubt that Dirichlet's remark should be taken seriously, and Weierstrass was particularly interested to clarify this problem and to recover this treasure. When in 1885 a prize was established at Mittag-Leffler's instigation for an important mathematical discovery, Weierstrass proposed precisely this problem as one of the prize questions, as was already mentioned. The committee consisted of Weierstrass, Hermite, and Mittag-Leffler. This led, then, to the famous work of Poincaré of over 200 pages which had a great effect on the later development of the subject. But for Weierstrass, who expressed his greatest admiration for this work of Poincaré, this was nonetheless a disillusionment, for Poincaré showed that the series developments of perturbation theory *in general diverge* and thereby Weierstrass' hopes appeared to be destroyed. By the way, these divergence phenomena bothered Poincaré

very little and he overcame them in a very bold manner. The asymptotic series developments that one uses in the theory of flows and other applied subjects go back to Poincaré's ideas, as does the use of divergent series in numerical calculations. Weierstrass, by contrast, pursued the convergence question mercilessly and found that, while Poincaré's deductions were quite correct, they did not in fact prove the divergence of the series in question. The existence theorems for quasi-periodic solutions, which we now know, say precisely that such series do converge for *certain frequencies*, and that was precisely Weierstrass' point. Thus, 70 years later, this question of Weierstrass can finally be given a positive answer. Naturally it is no longer possible to determine whether the new results actually coincide with Dirichlet's attempts or are related to them.

What has been said here should not give the false impression that mathematics is guided solely by such practical applications or that the justification of its existence is to be found in the solution of such problems. Rather it is the vigorous interaction of various areas of study that always leads to new

concepts. Is the solar system stable? Properly speaking, the answer is still unknown, and yet this question has lead to very deep results which probably are more important than the answer to the original question.

1. Es sollen für ein beliebiges System materieller Punkte, die einander nach dem Newton'schen Gesetze anziehen, unter der Annahme, dass niemals ein Zusammentreffen zweier Punkte stattfindet, die Coordinaten jedes einzelnen Punktes in unendliche, aus bekannten Functionen der Zeit zusammengesetzte und für einen Zeitraum von unbegrenzter Dauer gleichmässig convergirende Reihen entwickelt werden.

2. *Briefe von Karl Weierstrass an Sofie Kowalewskaya 1871-1891*, "Nauka", Moscow 1973

*Courant Institute of
Mathematical Sciences
New York University
New York, USA*

Jürgen Moser: Is the Solar System Stable? *The Mathematical Intelligencer*, 1 (1978), 65-71.